

STANDARD CONSTRUCTION

- FRAME:** 12-GA (.081" nominal) extruded aluminum. Hat channel with reinforcing bosses and groove inserts for silicone seals. Frame is 5" deep.
- BLADE:** 12-GA (.081" nominal) extruded aluminum. Single unit airfoil design, with the pin-lock an integral section within the blade core. 6" wide.
- SHAFTS:** 1/2" dia. extruded aluminum, pin-lock design interlocking into blade section.
- BEARINGS:** "Double-Sealed" type with celcon inner bearing on axle riding in polycarbonate outer bearing inserted in frame so that outer bearing cannot rotate; Axle bearings to be designed for no metal-to-metal or metal-to-bearing riding surfaces; Interconnecting linkage to have celcon bearings to eliminate friction in linkage.
- SEALS:** Extruded silicone rubber seal. Stainless steel spring jamb seal.
- LINKAGE:** In jamb. Aluminum crank-arm permanently locked to blade shaft by two stainless steel fasteners. Crank-arm contains a 1/2" dia., machined steel trunnion riding in a celcon bearing. a plated steel 1/4" - 20 set screw with locking patch ties the pivot to the 5/16" dia. aluminum linkage rod. Linkage of each damper is individually adjusted.

FINISH: Mill.

OPTIONS

- Hand Quadrants
- 120V, 24V, or Pneumatic Actuators
- Jackshafting
- Auxiliary Switch
- Explosion Proof Housing
- Clear anodize blades and frames (204-R1)

NOTES

1. Nominal deductions will be made to the opening size given.
2. Approximate shipping weight is 5.5 lbs./sq.ft.

DAMPER SIZES

Model	Min Panel	Max Single Panel
Parallel	12"W x 12"H	60"W x 72"H
Opposed	12"W x 14 5/8"H	60"W x 72"H

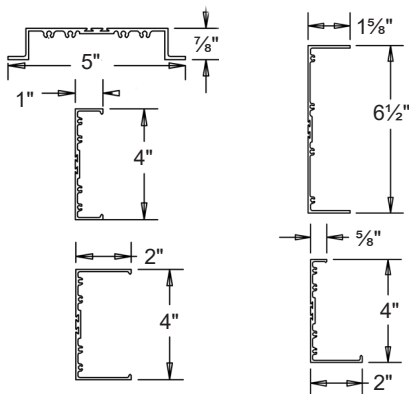

Optional Frames Available

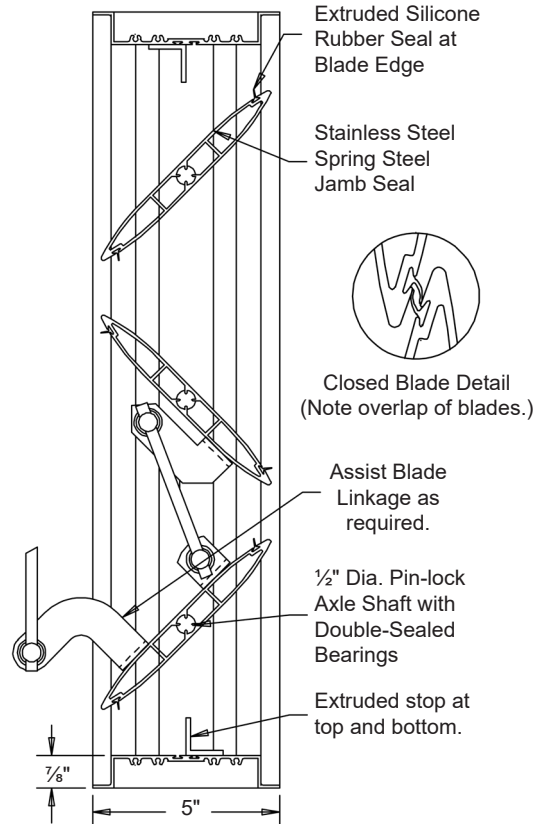

Model A29
Opposed Blade Damper

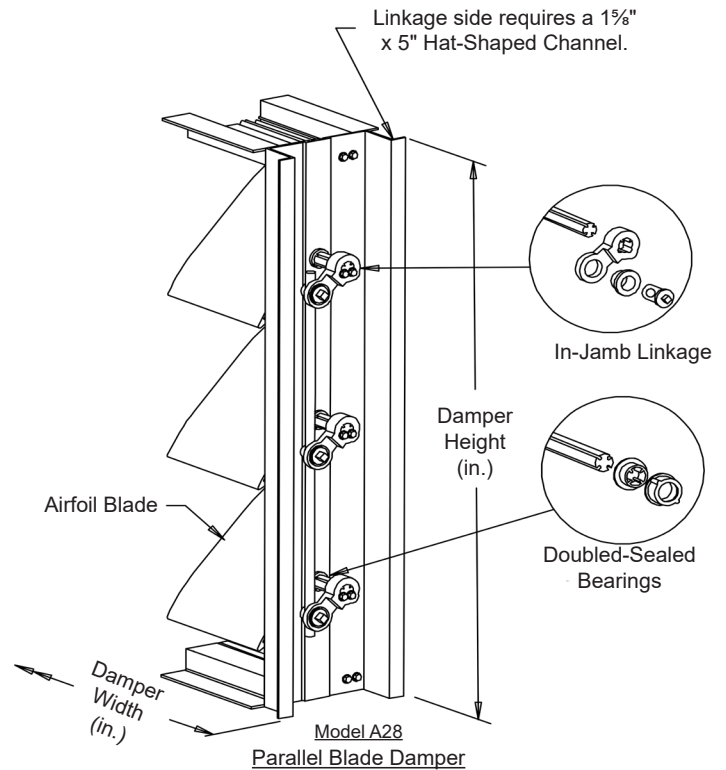

Model A28
Parallel Blade Damper

For handwritten orders, please use the schedule block on Page 2.

In the interest of product development, Louvers & Dampers reserves the right to make changes without notice.

www.louvers-dampers.com

450 Riverside Drive • Wyalusing PA, 18853 • Phone 570-746-1888 • Fax 570-746-9286

PERFORMANCE DATA

Pressure drop ratings are based on AMCA Standard 500-D using test set-up Fig. 5.3 for damper installed with duct upstream and downstream. Static pressures are corrected to .075 lb/cu.ft. air density.

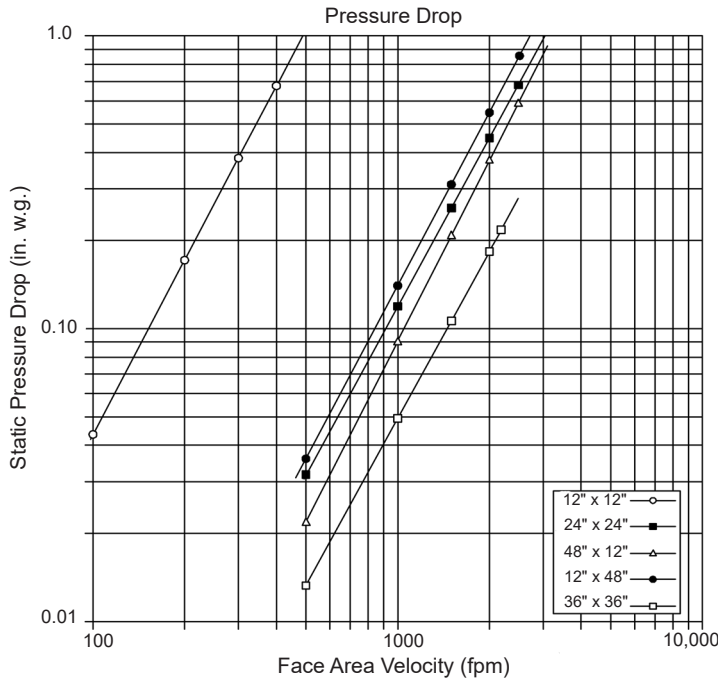

12"W x 12"H		24"W x 24"H	
Face Area Velocity (fpm)	Pressure Drop (in. w.g.)	Face Area Velocity (fpm)	Pressure Drop (in. w.g.)
100	0.04	500	0.03
200	0.16	1000	0.12
300	0.38	1500	0.25
400	0.69	2000	0.45
500	1.00	2500	0.68

12"W x 48"H		48"W x 12"H	
Face Area Velocity (fpm)	Pressure Drop (in. w.g.)	Face Area Velocity (fpm)	Pressure Drop (in. w.g.)
500	0.04	500	.02
1000	0.14	1000	.09
1500	0.31	1500	.20
2000	0.56	2000	.38
2500	0.85	2500	.58

12"W x 48"H	
Face Area Velocity (fpm)	Pressure Drop (in. w.g.)
500	0.01
1000	0.05
1500	0.10
2000	0.18
2500	0.21



Leakage
Air Leakage requirements meet International Energy Conservation Code (IECC) by leaking less than 3 cfm/sq.ft. at 1 in. w.g. of static pressure and is AMCA licensed as a class "1A" damper.

Damper Size	1 in. w.g. Class	4 in. w.g. Class
12"W x 12"H	1A	1
24"W x 24"H	1A	1
36"W x 36"H	1A	1
12"W x 48"H	1A	1
48"W x 12"H	1A	1
60"W x 36"H	1A	1

Air Leakage ratings are based on AMCA Standard 500 using test set-up Fig. 5.5 at an operation temperature range between 50°F and 104°F. Data are based on a seating torque of 40 lb/in for dampers less than 4 sq.ft in size. Dampers above 4 sq.ft, 5 lb/in/sq.ft. is applied to hold the damper in the closed position.

Damper Air Leakage Classification

Class/Pressure	Leakage cfm/ft ²	
	Required Rating	
	1 in. w.g.	4 in. w.g.
1A	3	NA
1	4	8
2	10	20
3	40	80

Louvers & Dampers certifies that the Model A28 - A29 shown herein is licensed to bear the AMCA seal. The ratings shown are based on tests and procedures performed in accordance with AMCA Publication 511 and comply with the requirements of the AMCA Certified Ratings Program. The AMCA Certified Ratings Seal applies to Air Performance and Air Leakage Ratings only.

				 Union Made
Item #	Qty	"A" Dimension	"B" Dimension	
Arch. / Eng.:				
Contractor:				
Project:				
EDR:		ECN:		Job:
Date:		DWN:		DWG:

AIR LEAKAGE PERFORMANCE

Test units were installed in ductwork with duct upstream and downstream in accordance with AMCA test set-up Fig. 5.3. Using most common approach velocities and fan static pressures to conduct linear air flow test.

The results of the tests show that fan static pressure does have an effect on the linear air flow characteristics of a damper. These graphs will identify the simulated system conditions used for the single damper in duct system application.

Curves shown in these graphs demonstrate that the Model A29 opposed blade damper "as standardly built" is a very effective control damper for use in a variety of velocities and pressures.

